



WINDOW, DOOR & SEALED UNIT FABRICATORS

Today's trade choice for tomorrows business rewards...





- Same day quotations
- 5 Day nationwide delivery
- Free technical advice
- Dedicated customer support team
- CAD service
- A & C rated windows
- Bespoke products
- Marketing support

Flair have been supplying the trade for many years, and are one of the country's leading fabricators of UPVC windows, doors, conservatories and a wide range of sealed units all certified to Kitemark BS EN 1279:2. A holder of management System ISO 9001:2000 where quality and customer service are paramount, Flair continues it's commitment and expertise to help customers grow profitably.

Operating from our state of the art factory with fully equipped machinery, we fabricate the Kommerling O70 & C70 five chambered energy efficient window systems. We also fabricate PremiLine & PremiDoor patio doors, the fitter friendly Global conservatory roofing system, astragal bar windows, sealed units, composite doors and UPVC door panels.

Our dedicated customer service team are always on hand to answer your enquiries. We offer expert advice on all of your technical issues, whether you have a fitting query or need an update on how to comply with current building regulations, you can rest assured we are here to help.

Based in the centre of England we are perfectly situated to deliver our wide range of products across the country. We are never too far away from anyone and this is why our 5 day turnaround is actually a maximum and in most cases we can beat this.



“We know its often easier to stay with existing suppliers, but are you really getting the best service and price?”

At Flair we are constantly evolving to meet the needs of our customers, we are continually investing in our business to enable us to support yours.

We also offer marketing support packages to help you communicate your business effectively. We can supply you with brochures in your brand, profile colour sample boards, product brochures and specification guides on all of our products, quotation and check list templates and showroom support. We are always open to discuss any other products and literature to help support your business - just ask!

Why not send us your next quotation request and see how we compare, what have you got to lose? There's no hassle, no commitment just honest prices and great service.

You can order your consumables through us too, saving you time and money. Just let us know what you need and we'll add it to your delivery.

So fax, phone or e-mail us and experience the Flair difference.”

*Peter Lugg
Managing Director*



Quality	4
Delivery	5
Windows	6-9
Conservatory Roofs	10-11
Patio Doors	12-13
Bi-Fold Doors	14
UPVC Doors	15
Composite Doors	16-17
Environment	18
Energy Efficiency	19



KM 96507

Certified Sealed Units

Our units are certified to Kitemark BS EN 1279:2.

The Kitemark is a BSI certification is an internationally recognised mark that represents quality, reliability and continual improvement.

It shows that our products have been rigorously tested by BSI and have met the strict industry standards and CE marking. Our units are subject to further periodic testing and assessment to ensure the standards are maintained.



FM 96527

Holder of ISO 9001:2008

ISO 9001 is the principal internationally recognised standard for Quality Management Systems.

As a business with ISO 9001:

- We have demonstrated that we consistently provide products that meets customer and applicable regulatory requirements
- We have proved that we are committed to enhancing customer satisfaction through the effective application of the system. This includes processes for continual improvement of the system and the assurance of conformity and applicable regulatory requirements.



CE Compliant

CE marking is a key indicator of a product's compliance with EU legislation and enables the free movement of products within the European market.

Our finished products are CE marked, meaning that we assume sole responsibility and conformity with all of the legal requirements to achieve CE marking and therefore ensuring validity for that product to be sold throughout the EEA, the 27 member states of the EU and European Free Trade Association countries.

By buying your frames and glass together from us you can be assured that you will be compliant with CE regulations.

Our CE marking means that we have verified that the product complies with all relevant essential requirements, eg health and safety requirements, of the applicable directive(s) or, if stipulated in the directive(s), had it examined by a notified conformity assessment body.

It means we have:

- Carried out the conformity assessment
- Set up the technical file
- Issued the EC Declaration of Conformity (DoC)
- Affixed CE marking on the product

Our CE certification can be found on our website.

Same Day Quotation

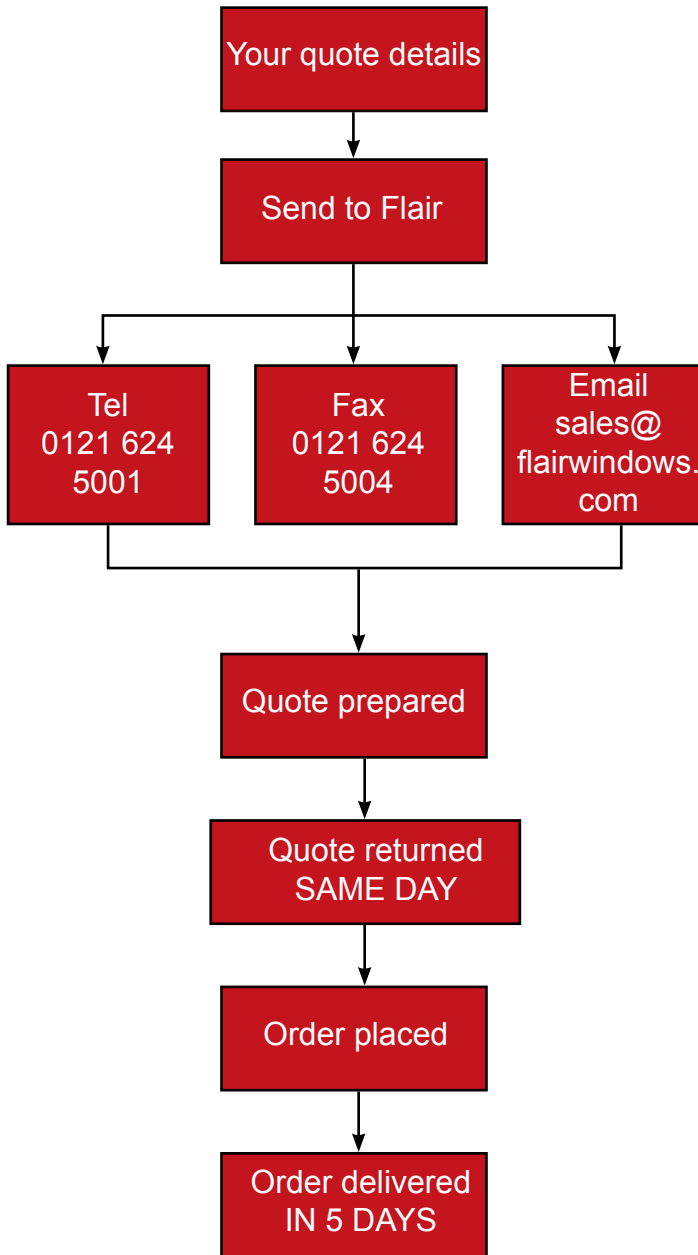

5 Day Delivery

Nationwide 5 day delivery, or sooner. For areas outside of these regions please call for details.



- Monday
- Tuesday
- Wednesday
- Thursday
- Friday



Profiles

Ovolo O70 System.

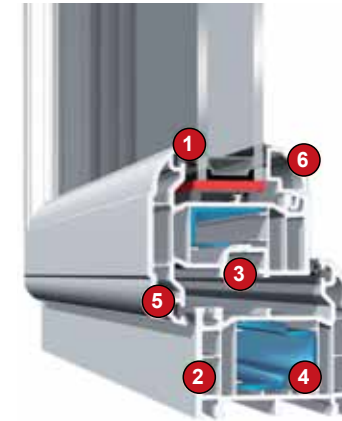

Chamfered C70 System.

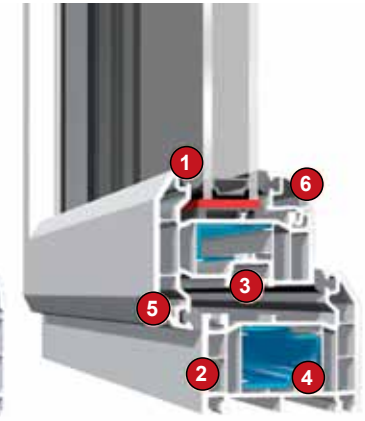

- Kommerling O70 & C70 Profiles
- 5 Chamber Profiles
- Planibel A Glass
- Warm Edge Spacer Bars
- Internally Beaded
- High Security Locking System
- Same Day Quotations
- 5 Day Turnaround



KÖMMERLING®

We manufacture and install the energy efficient KOMMERLING O70 & C70 5 chamber Gold Systems.

Both profiles offer a 70mm frame depth, extruded using a colourfast lead-free UPVC Greenline compound. The ovolo design of the O70 has a curved frame and opening sashes create a 'softer' appearance adding a little design flair to any installation. The C70 gives a modern look with its clean chamfered design.

Both profiles are combined with high security multi-point locking and internal beading for enhanced security.

The O70 & C70 systems are highly regarded as amongst the easiest to install and can be complemented with a front/rear door, PremiLine patio, bi-fold, lift and slide or a conservatory.

- 1 Black gaskets and weatherseals, provide lasting performance and slimmer sightlines.
- 2 Five chambered system is more energy efficient than the 3 chambered designs from many of our competitors.
- 3 The full depth, central eurogroove helps make the windows and doors more secure.
- 4 Steel reinforcement is used where needed, to add additional structural strength.
- 5 The ovolo design of O70 Gold shows off soft sculptured lines in the frame, sash and glazing bead, while the C70 Chamfered design gives a modern and clean look through the frame sash and bead.
- 6 Single leg glazing bead is highly secure and easy to install on site.

Heritage Windows



Integrated spacer bar for an authentic finish

ASTRAGAL BAR

Astragal Bars can be fitted to any product enhancing the look of windows, doors & conservatories by giving them the traditional Georgian appearance of individual panes. They are available in white or woodgrain foils.

The Astragal Bars are securely fitted by the use of 'clips' wrapped around the sealed units and centre clips with adhesive pads specially developed to adhere to glass in all weathers. When 'grids' are specified, they will be factory fitted to save time 'on site'

- Option of either chamfered or featured Georgian Bar.
- Comprises of edge clips, centre clips, and bars with mitred ends.
- Both bars are 25mm wide and 16mm deep for an authentic finish.
- Can be toe and heeled during installation.
- Removes issue of failed 'stick on' alternatives.
- Provides a more authentic finish.



RUN-THROUGH SASH HORNS

Run-Thru Sash horns create an attractive alternative to the traditional vertical sliding window. Available in both white and foiled options they are designed to appeal to homeowners looking to replace traditional sash box windows with a more cost effective and virtually maintenance free alternative.

These are fabricated by milling the profile into shape as opposed to the less effective screw on method.

The system provides safe cleaning of both sashes from the inside, security, high performance and aesthetically pleasing designs. Where required profiles can be formed to provide arch heads to match existing building details.

- Sash horn option for O70 Gold system.
- One piece sash horn end cap with an integrated gasket.
- Dedicated die cast universal fixing bracket for mechanical sash joints.

FRENCH WINDOWS - FLOATING MULLION



French windows are designed to appeal to owners with small casements and also those looking for a traditional appearance.

The floating mullion allows both sides of the window to be opened and offers an unobstructed view, creating a feeling of space. They are also ideal as a 'fire escape' solution where normal casements may not comply.

- O70 or C70 profile.
- Side opening casements.
- Unobstructed view.
- Ideal fire escape solution.

Tilt & Turn

This popular window style offers all the benefits of a large glazed area with its ease of cleaning and smart contemporary style. The sophisticated mechanism enables the window to be opened inwards from the top to allow for ventilation or from the side for ease of cleaning.



Spacer Bars

SGG SWISSPACER®

Lower heating costs through better insulation: The thermally improved spacer SGG SWISSPACER V excels with an optimised heat transfer resistance. The result: The high tech spacer bar SGG SWISSPACER V enables heating costs to be reduced by up to 5%.

- 1 Superior isolation characteristics mean higher temperatures are maintained at the edges of glass panes – significantly reducing the risk of condensation.
- 2 Higher temperatures at the edge of the pane mean less cold radiation, ensuring more comfort inside and a healthy indoor climate.
- 3 The high-quality plastic of SGG SWISSPACER in combination with a unique colour range means you can design each window and any façade to your specification.

Glass

PLANIBEL A Clear advantages

PLANIBEL A, is a revolutionary new energy efficient glass with a high performance, low-emissivity hard coating specially developed to perform to the highest ratings within the Window Energy Ratings scale from C to A, without the need for edge deletion.

- 1 High solar factor, which maximizes the free solar heat gain (SF: 78% with external sheet PLANIBEL Clearvision).
- 2 Low Ug-value that can further be improved by the use of gas filling (Argon) and/or the use of a Warm Edge spacer.
- 3 Draws energy in from solar power and retains it, providing the best energy rating system, particularly when combined with the Swiss Spacer Bar.



Pilkington Optiwhite™

Extra clear, low iron glass with very high light transmission.

Pilkington Optiwhite™ is a low iron extra clear float glass with very high light transmission. It is practically colourless, and the green cast inherent to other glasses is not present.

It is therefore ideal for use where glass edges are visible or where a neutral colour is desired. As its light transmission is higher than clear float glass, it is perfect for applications where transparency and purity of colour are desired.

When Pilkington Optiwhite is used as the outer pane of an insulating glass unit the solar energy transmissions (solar gain) is increased, enabling the unit to achieve a higher window energy rating (WER) and therefore a higher level of thermal efficiency



Pilkington Optifloat™ Clear

Pilkington Optiwhite™

Flair sealed units are made using Planibel A as the inner pane and Pilkington Optiwhite as the outer pane, we use Swisspacer bars and fill with argon gas. These products and processes combined achieve a superior energy efficient unit.

Textured Glass



For privacy, pure style or to allow more light into internal rooms, decorative glass gives you a whole range of attractive options. In fact, Pilkington gives you a choice of no fewer than 18 different textured glass designs, together with our premium range of etched glass – from classic to contemporary, no one offers a bigger choice.

The advantages of Pilkington decorative glass are easy to see: it allows maximum light while maintaining privacy or obscuring unattractive views, and also forms an attractive decorative feature itself.

Window Locks

All opening windows are secured using the Twin-Cam Security (TSL) locking system that has revolutionised window fabrication and security; with exceptional levels of performance it offers the ultimate in casement window security and fabrication efficiency. TSL enables windows to comfortably meet, and exceed, the requirements of BS 7950 and has proved to be stronger than many shootbolts. A simple turn of the handle drives TSL's twin-cams into a double-sided strike to deliver significantly enhanced resistance to jemmying from all directions.

Side opening windows can be hung with egress hinges to allow for ease of cleaning from inside



Handles

We have a wide range of handles and accessories in different colours, finishes or designs.



Profile Colours

Besides white, windows are also available with a foil coating in different colours or wood grain patterns on one or both sides. We stock the following:





Innovatively designed make life easier for fitters while ensuring satisfaction for the end user. Sight-lines are co-ordinated to ensure that the final product is aesthetically pleasing while designed from the ground up to fit together quickly and with ease.

The special glass kit is designed to give you an extra pair of hands when fitting glass in conservatory roofs and the super heavy weight glazing sections remove the need for steel inserts. All polycarbonate roofs are 35mm thick and all roofs have sealed gaskets.

Available in 35mm polycarbonate or glass, including the revolutionary self cleaning glass from Pilkington.

Polycarbonate

Available in:-



Clear



Opal



Bronze

Self Cleaning Glass

Unique coating breaks down and loosens organic soiling

Pilkington Activ™ Range

The world's first self-cleaning glass with advanced dual-action for superior results.



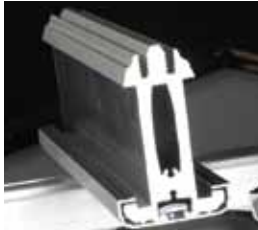

High strength rafters

Our rafter bars are designed for increased loads so you don't have to compromise on design or weather performance.



Low level gasket system

No one wants to look at their conservatory roof and see thick black gaskets around every glazing bar. That's why we have designed our roof with concealed gaskets.



Aluminium top caps

Our woodgrain and painted top cappings are made from aluminium so will not warp or distort under extreme heat or split under extreme cold.



Perfect lead flashing

The lead dresses into a built-in soaker forming a watertight seal with no need dress lead over the top cap, preventing any unsightly lead lines or staining.



Single fixing bolt

The unique single fixing bolts are fastened internally for easy and quicker installation. We do not penetrate the main aluminium rafter so there are no fixing holes for water to ingress through.



End caps

Our end caps have a shoulder around the visible face for a more attractive appearance and have been designed with built-in drainage to relieve any trapped water.



Tie bolt

Our precision engineered security locking bolt eradicates movement between the bolt and rafter, to give a strong and rigid anti-slip joint connection.

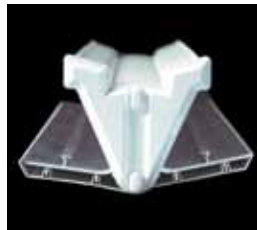

Variable valley

The valley is designed to suit varying pitches and angles and is cloaked internally and externally to give an attractive aesthetic finish.



- Kommerling Profiles
- Planibel A Glass
- Warm Edge Spacer Bars
- Internally Beaded
- High Security Locking System
- Glass or Polycarbonate Roofs

PremiLine Patio Doors



2, 3 and 4 panes

Our patio doors are made using Europe's number one profile KOMMERLING. They have a chamfered design and smooth quiet running. Our long lasting, reliable and comfortable sliding door system has an aluminium-reinforced centre section. This provides a high degree of stability, security and tightness. It also means the ability for larger window areas and sliding elements than ever before. Our sliding door system is compatible with all 70mm systems.

The Kommerling PremiLine sliding patio door is packed with technical features and is extruded using our Greenline lead-free PVCu compound. There are relatively few systems companies harnessing lead-free compounds for extrusion and even fewer producing an environmentally friendly, sliding patio door system. It's also the perfect match to our C70 and O70 systems and given the innovative design of the outer frame which is 70mm deep tapering out to 80mm to accommodate the sash, it can be easily can easily be coupled to any Kömmerling 70mm frame and benefits from a large range of ancillaries.

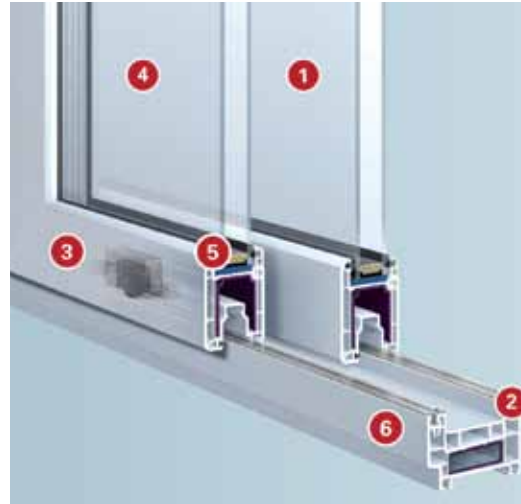

- 1 Can offer 2,3 or even 4 panel openings.
- 2 High quality stainless steel tracks guarantee the maximum possible service life.
- 3 Extremely smooth running sliding doors, moving at the slightest touch.
- 4 Offers high security and large units are easily achieved.
- 5 Striking design with a choice of low sightline gaskets in black or grey.
- 6 Outer frames can be welded or mechanically jointed. Low threshold option also available.
- 7 Option of full length aluminium handle for further stability (not shown).

When selecting the glazing there are a whole range of options to choose from. We have different pane casements available to make sure your customers can enjoy the maximum possible window space in terms of both height and width. The systems inherent flexibility makes it ideal for all kinds of openings.

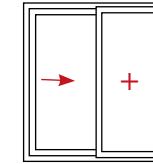

Two part element with one sliding door and one fixed pane

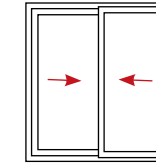

Two part element with two sliding doors.

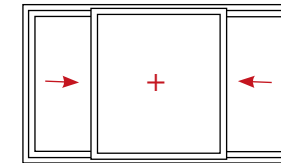

Three part element with two sliding doors and one fixed pane in centre

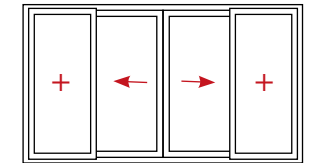

Four part element with two sliding doors in the centre and one fixed pane on each side

Useful variations: On request, a letter box can also be integrated into your sliding door.



PremiDoor Lift & Slide - Extraordinary Measurements



The Lift and Slide door is a genuine alternative for a bi-folding door and with less PVCu sightlines, and more glass in which to see the world outside. The product is designed for large openings in the home or conservatory and is capable of openings of up to 6 metres with just two sashes.

There's also the option of 2, 3 and 4 pane door systems which are capable of spanning over 10 metres. The running track has been specifically designed for lasting performance and ease of use. There's also a thermally broken frame that provides energy efficiency and the necessary structural integrity to carry a large sash with ease. Like all of our window and door systems, it's extruded with our lead-free Greenline compound.

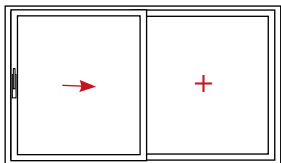

Double pane option with moving left hand and fixed right hand sash

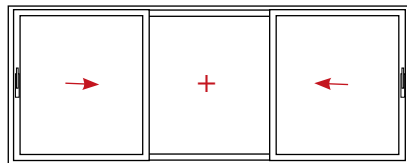

3 pane option with moving left hand and right hand sash with fixed middle

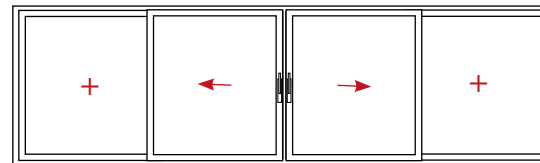

4 pane option with moving centre sashes and fixed left and right hand sashes

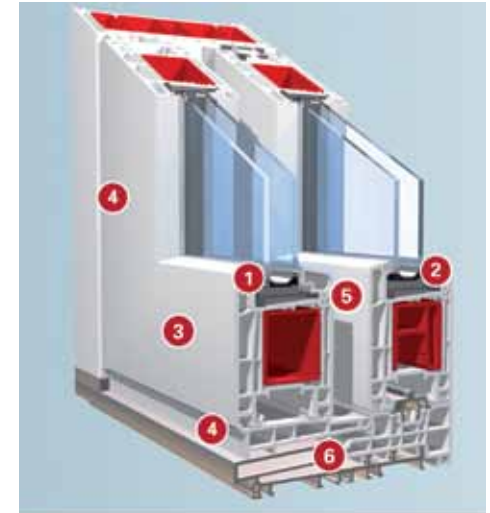

- 1 Low line gaskets and weatherseals provide lasting performance and slimmer sightlines.
- 2 Single leg glazing bead is highly secure and easy to install on sight.
- 3 Reliable functionality, great handling and smooth and quiet running of the sliding sashes.
- 4 Extraordinary measurements: sash sizes up to 3.0m wide and 2.5m high. Up to 4 sashes.
- 5 All PVCu profiles are extruded in our exclusive lead-free Greenline compound.
- 6 Outstanding thermal insulation threshold with thermal break for optimal isothermal properties.





Our bi-fold and multi-fold door systems are made using Europe's number one profile, Kommerling and Fuhr high security locking system. They offer smooth and simple operation. They have a chamfered 70mm design and run on maintenance free stainless steel concealed rollers. Doors can be easily folded back to left or right and can be specified to open inwards or outwards.

This new system can facilitate 3, 4, 5, 6 or even 7 sashes and is capable of spanning 5.7m with maximum sash sizes of 2.2m. The stunning aesthetics of the door are enhanced with the option of either bevelled or ovolo glazing beads and low lying gaskets for better sightlines.

These bi-folding doors harness 5 chambered profiles for better energy efficiency when many other companies products have just 3. All profiles are fully reinforced to add structural stability, while the powder coated aluminium tracks guarantee the maximum possible service life. Like all Kommerling systems, the bi-folding door is available in a wide range of colours and woodgrains.

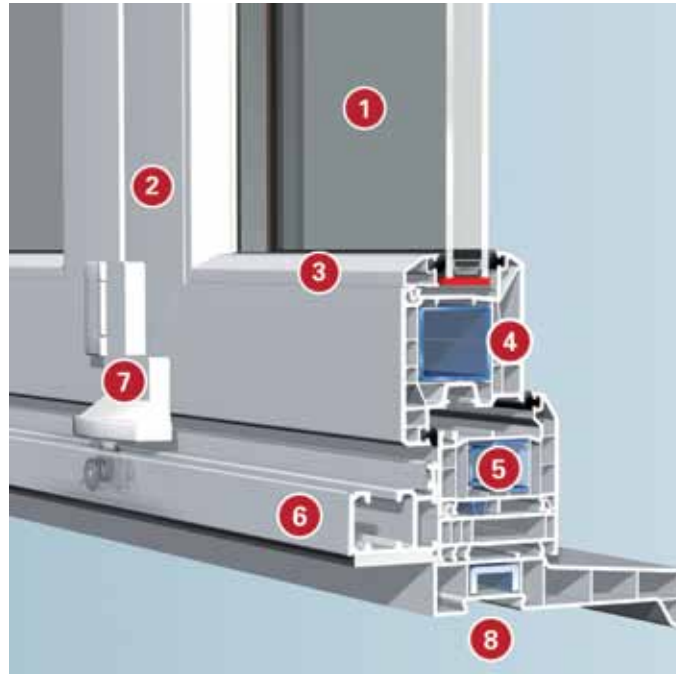

- 1 Option of 3, 4, 5, 6 or even 7 sashes.
- 2 Capable of spanning 5.7m with sash sizes of 2.2m high x 0.8m wide.
- 3 Beautiful design with the option of bevelled or sculptured glazing beads with low lying gaskets.
- 4 Five chambered profiles for improved energy efficiency.
- 5 Fully reinforced to add structural stability.
- 6 Powder coated aluminium tracks guarantee the maximum possible service life.
- 7 Impressive smooth sliding doors, folding with ease of movement at the hinge.
- 8 All PVCu profiles manufactured using our exclusive lead-free Greenline compound.

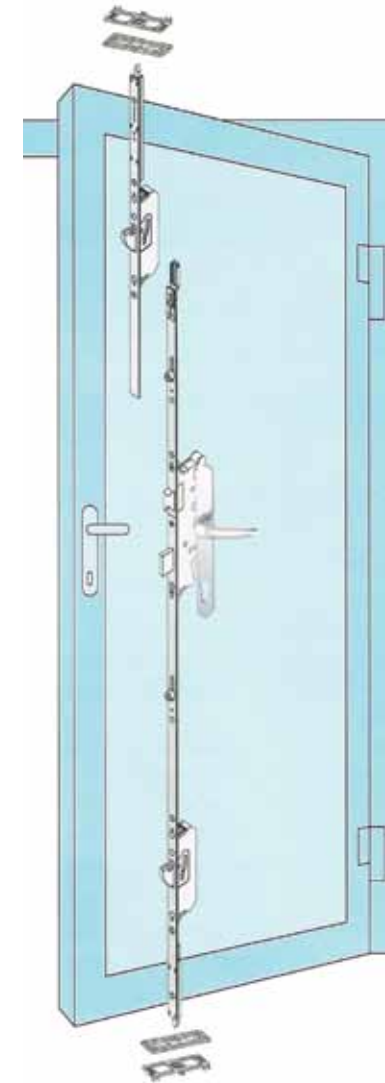

HEAVY DUTY LOCKING

Features

- Stainless steel
- 100% corrosion resistant
- Trouble free operation
- 10-year guarantee

Benefits

- Durability
- Reduced call-outs
- Excellent appearance
- Security



- Stainless steel deadbolt
- Reversible latch
- Standard dimensions
- Heavy duty FUHR hooks (extending 20mm)
- Free running, adjustable roller cams

UPVC - Front Door Panels

We have a comprehensive range of styles available, or feel free to design your own using one of our profiles. Choose leaded, stained glass, patterned glass or Georgian bar.



- Kommerling profiles
- Low line gaskets
- Steel reinforced welded profiles
- Multi-point locking & shoot bolts
- High security
- Internal beading
- Colourfast PVCu
- 28mm sealed units
- High impact profiles
- Choice of handle colours
- Choice of hinge colours



Back Doors French Doors



Our UPVC doors are made using Kommerling steel reinforced welded profiles. They feature low line gaskets and have a robust multi-point locking system and strong hinges which are available in different colours.

These high security doors are virtually maintenance free as they are made using colourfast UPVC. The range of designs means that there will be something to match virtually any house of any age.

Available in a range of colours and a choice of handle colour these high performance doors combine looks with security and longevity.



White

Gold

Chrome



Composite Doors

Our Solidor range is an outstanding collection of unique solid laminate 48mm timber core composite doors that combine classical or modern styling with high security locking which provides a stunning, high quality and secure entrance to any home.

These exclusive doors are available in a wide range of style and colour options and various low threshold options both UPVC and aluminium, making it the perfect solution for easy wheel or push chair access.

GUARANTEE

As you would expect from a market leading product, that's a result of a comprehensive product development programme, we offer a complete product guarantee. The warranty covers the door construction, finish, lasting performance, glass, hardware and all other accessories.



SPECIFICATION

All of our doors are based on our proven 48mm design that is 10% thicker than our nearest competitors. Our hardware and accessories are also sourced from world leaders in their respective fields and importantly, are free from harmful lead additives.

Lead free, 5 chamber profile with 100% recycled reinforcing

Thermally efficient solid timber core

Robust through colour thermo plastic skins

Realistic wood grain effect or smooth finish

Optional integral mobility access aluminium threshold

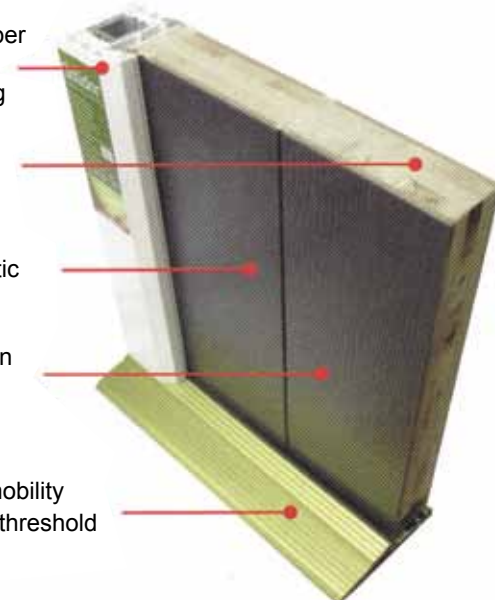



COLOURS

Our colour range is by far the widest in the market and now amounts to 16 colours and woodgrains inside and out, including a number of exclusive finishes such as Mocha and Duck Egg blue. We can even offer a range of 18 colour combinations for the door frames. Our doors are 'through colour' not just a simple gel finish or stain on the surface.

STYLES



The Italia Collection



The Conway Range



The Harlech Range



The Ludlow Range



The Beeston Range



The Windsor Range



The Nottingham Range



The Thornby Range



The Stafford Range



The Tenby Range



The Flint Range



Stable Doors

SECURITY



DOUBLE & TRIPLE GLAZED UNITS
Manufactured to BS EN 1279 using 4mm toughened safety glass for double glazed sealed units and a mixture of laminated glass and toughened glass for triple glazed sealed units.



MAGNUM SECURITY
For extra security and piece of mind upgrade to the Magnum cylinder. It has been tested to the highest grade of BS EN 1303 for security achieving the maximum resistance to physical attack.



COLOUR FASTNESS GUARANTEE
All doors have a guaranteed UV stable colour fastness. All Foiled products match, so that the door and the frame match together.



KEY OPERATED MULTI
For those who prefer not to have a handle on their door. This upgrade option offers a key operated multi point lock.



MULTIPOINT LOCKING
A wide range of multi-point locking, standard handle operated, night latch and key operated multi or just key only multipoint locking, security is never compromised.



At Flair we take environmental issues seriously and believe it our duty to protect the planet. We only select suppliers and materials that follow our ethos.

Kommerling have been sensitive to the environment for many years and that includes their unique Greenline, lead free compound, that's inherent in all of our window and door systems.

We also operate Recycline, a process of collecting any scrap UPVC materials from customers for recycling. This includes old first generation UPVC windows that we are replacing, right across the UK.

Products such as SWISSPACER and PLANIBEL A mean lower heat requirements through better insulation and maximising solar energy. This benefits the environment in several ways. There is no need to extract, transport, supply and process additional energy, this not only saves resources but also decreases the level of CO2 emissions in the environment.

Our composite doors from Solidor are 100% recyclable, all timber that is used is harvested from sustainable sources and complies with FSC regulations. These doors are manufactured in the UK minimising the carbon footprint. They are lead free and designed with a thermally efficient enforcing system.



KÖMMERLING®

The Kommerling system has long-lasting plastic profiles that have been stabilised using environmentally friendly calcium-zinc and have an extremely low maintenance requirement. In contrast to wooden profiles, they never need painting.



greenline

Greenline - our commitment to the use of lead free materials.



recycline

Recycline - our commitment to the recycling of waste UPVC materials.

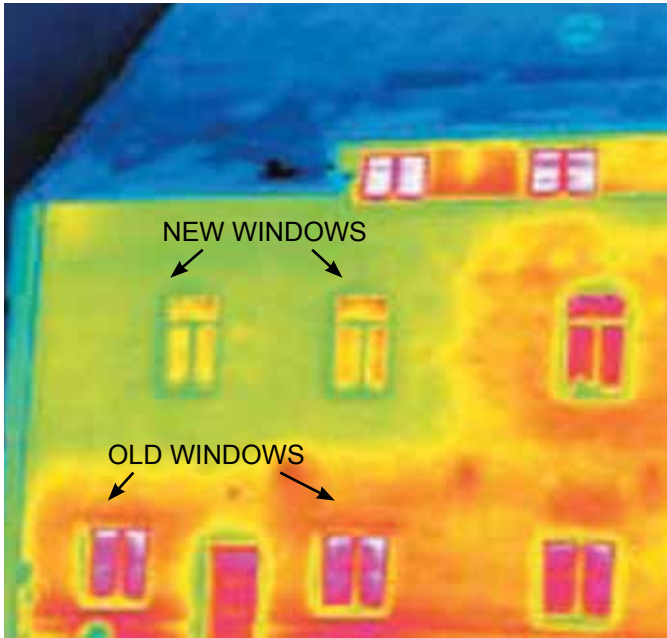

The thermal image of the house above, shows the green areas (top left) where old windows have been replaced with modern energy efficient ones, in contrast to the old existing windows shown in magenta, which let considerable heat out of the home.

The image below shows the warm edge effect of SWISSPACER. The dark blue areas showing reduced temperature or up to 5.3° when standard spacers are used.

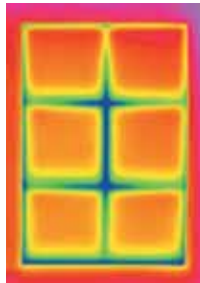
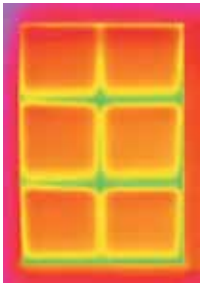

With SGG SWISSPACER. Without SGG SWISSPACER.

SGG SWISSPACER®

What is a “Warm Edge”?

At the edge bonds, a “gap” is created between the double glazing panes with the help of spacers. This creates a space filled with inert gas or air between the glass panes, a key factor for the insulating efficiency of the glazing. The spacers create a linear thermal bridge of considerable length within the window component. When metal profiles are used, thermal heat is more or less released into the atmosphere – along the entire transition area between glass and window frame.

PLANIBEL A

Once assembled in double glazing PLANIBEL A provides: A high solar factor, which maximizes the free solar heat gain (SF: 78% with external sheet PLANIBEL Clearvision)

A low Ug-value that can further be improved by the use of gas filling (Argon) and/or the use of a Warm Edge spacer.

PLANIBEL A is a revolutionary new hard coating that meets the highest glass performance expectations for Window Energy Ratings (WERs) without the need for edge deletion. Thanks to its unique “fast” technology,

PLANIBEL A offers unrivalled processing performance with faster toughening cycles of up to 15% over traditional hard coatings and up to 25% improvement in comparison with alternative soft coating solutions.

With exceptional performance and enhanced processing benefits, helping your customers to achieve WER ratings of C to A using PLANIBEL A could not be easier, PLANIBEL A has taken hard coatings to the forefront of glass technology making it the right choice for both the processor and window manufacturer.

The combination of carefully selected materials, expert process and careful waste disposal make Flair products among the most energy efficient and environmentally friendly on the market.

Window Energy Rating

Flair Plastic Products Ltd	
UPVC Casement Window A	
Reg No. 0197-002A	Date.05/11/2010

Thermal Rating Register	0 +	A	Energy Rating <small>kWh/m²/year of energy consumption</small>
	-10 to < 0		
	-20 to -10		
	-30 to -20		
	-50 to -30		
	-70 to -50		
	-70 +		

The Window Energy Rating is a relative rating based on a notional house and windows in an average UK location. Actual energy performance will vary with building detailing, usage, local climate and internal temperature.

To Check this label is current visit:
www.thermalratingregister.org

- Sealants
- Trims
- Adhesives
- Tools
- Fixings
- Cleaning
- Hardware
- Roofline



Fully Stocked Trade Shop - online or in store



Our trade counter is open Mon-Thurs 8am-4.30pm, Fri 9am-4pm, Sat 8am-1pm

Shop online or call the trade counter and ask for a brochure. Add your items onto your order and we'll deliver together.

www.flairwindows.com

Flair Plastic Products Ltd

Unit 36 Minworth Industrial Park
Forge Lane
Minworth
West Midlands
B76 1AH

T: 0121 624 5001

F: 0121 624 5004

E: sales@flairwindows.com

W: www.flairwindows.com